

Alabastro Italiano
ITALY

COMPANY INTRODUCTION 3

MATERIALS AND FINISHING 5

NEW COLLECTIONS

APPLIQUE

HIKARI 6

HIMEJI 10

KINKAIRO 14

KENDŌ1 18

KENDŌ2 22

TSUKI 26

SUSPENSION

HAKUYORU 30

FUTATSU 34

DEMETRA ROUND 38

FURNITURE

SERENITY FUSION 42

SEKISHO 48

TRACK/SPOTLIGHTS

OGI 52

HENKA 66

ENKŌ 70

SPECIAL SYSTEMS

EDEN WALL PANELS 74



Alberto Ongarato



Riccardo Ongarato

After years of experience in the family business, which specializes in design and lighting, Riccardo and Alberto Ongarato found the brand Alabastro Italiano. Each project is conceived and designed to give a strong sign of recognizability and uniqueness. The use of precious materials such as alabaster, brass, leather and blown glass, worked by the skillfull hands of our craftsmen, are combined to create “timeless” objects.



What is **Alabaster**

Alabaster needs human hands to come to life. The charm of these stone objects comes from their uniqueness, from the fact that they come from the hand of those who has left a mark and a memory with their work.

Alabaster is a compact and rare stone, that lays down very precise laws, requires a familiarity that only Italian craftsmen possess.

Metal finishes



Shiny Silver



Bronze



Brushed Brass



Ruggine
of Florence



Brushed
Burnished



Shiny Gold



Brushed Black



Freedom Green



Shiny Black



Copper



Matt Black



Hikari applique

Hikari (光) embodies the profound symbolic meaning of light, derived from the kanji which depicts a man holding the light. This homage to ancient beliefs that venerated sacred fire and entrusted wise shamans with its protection gives Hikari a symbolism of extraordinary elegance and grace. Its warm and embracing light, imbued with rich cultural meanings, illuminates the spaces in which it is found.



Hikari applique

Materials

Alabaster

Finishes

Shiny Silver, Bronze, Brushed Brass, Ruggine of Florence, Brushed Burnished, Shiny Gold, Brushed Black, Freedom Green, Shiny Black, Copper, Matt Black, Wood

Light source

2 x G9, 4 x G9
3000 K

Dimensions

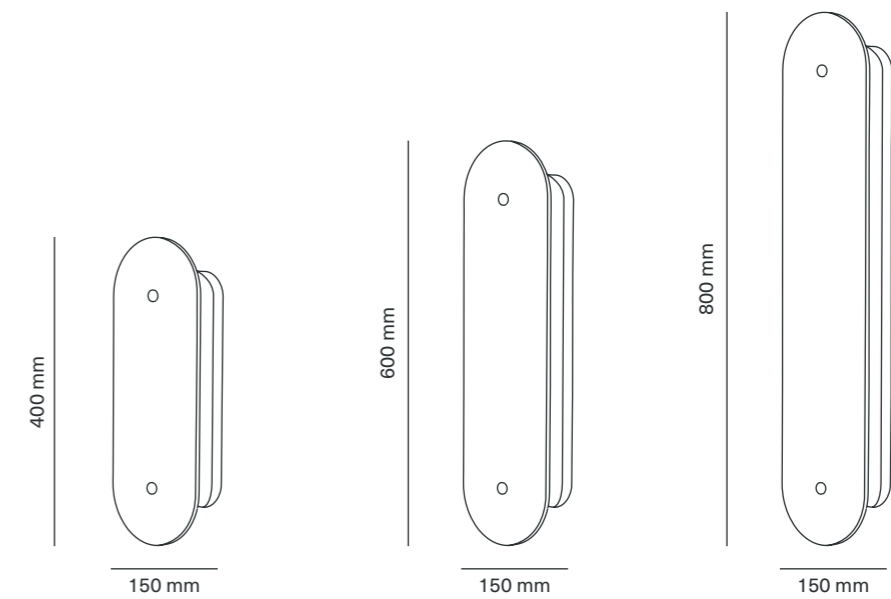



Himeji applique

Himeji (姫路市) taking inspiration from the renowned Japanese city, is an extraordinary fusion of fine materials and craftsmanship. Its elegant shape features a slab of alabaster, symbol of purity, joined precisely in the center by a rectangular black leather part. This combination of elements represents a perfect harmony between tradition and modernity, in a homage to the famous Himeji leather work.



Himeji applique

Materials	Alabaster, Leather
Finishes	Shiny Silver, Bronze, Brushed Brass, Ruggine of Florence, Brushed Burnished, Shiny Gold, Brushed Black, Freedom Green, Shiny Black, Copper, Matt Black
Light source	2 x Strip LED, 21,6 W/m 3000 K

Dimensions

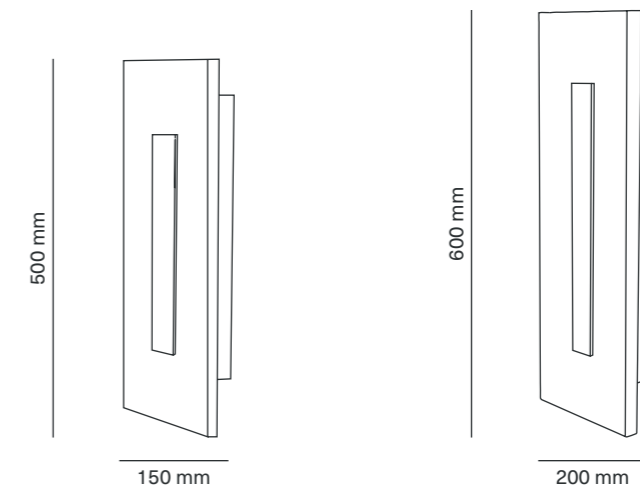



Kinkairo applique

Kinkairo (金灯笼) embodies the essence of the Japanese lantern tradition. Its shape, inspired by the symbolism of Japanese lanterns, represents enlightenment and deep religious understanding. This product is a tribute to the tradition started by Sen-no-Rikyu, who used lanterns to light his evening ceremonies in the 16th century. Kinkairo, with its design evoking the delicacy of these lanterns, carries the beauty imbued with cultural and spiritual meanings, creating an atmosphere of calm and contemplation in any environment. Kinkairo goes beyond its function, transforming spaces into places of refined serenity and deep connection with tradition.



Kinkairo applique

Materials	Alabaster
Finishes	Shiny Silver, Bronze, Brushed Brass, Ruggine of Florence, Brushed Burnished, Shiny Gold, Brushed Black, Freedom Green, Shiny Black, Copper, Matt Black
Light source	1 x Strip LED, 21,6 W/m 3000 K

Dimensions

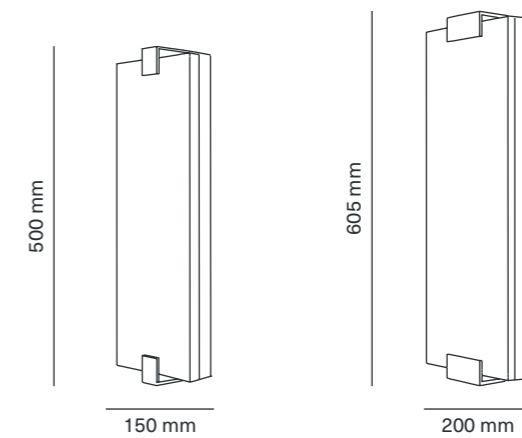



Kendō 1 applique

Kendo (剣道) inspired by the profound philosophy of the 'way of the sword,' represents an elegant blend of tradition and contemporary minimalism. Its cylindrical shape, sleek with precision, evokes the sharpness and purity of a Japanese katana. Kendo embodies the essence of a sword of light cutting through the darkness, creating an atmosphere of strength, refinement and clarity. This product manages to combine tradition with innovation.



Kendō 1 applique

Materials	Alabaster
Finishes	Shiny Silver, Bronze, Brushed Brass, Ruggine of Florence, Brushed Burnished, Shiny Gold, Brushed Black, Freedom Green, Shiny Black, Copper, Matt Black
Light source	1 x Strip LED, 21,6 W/m 3000 K

Dimensions

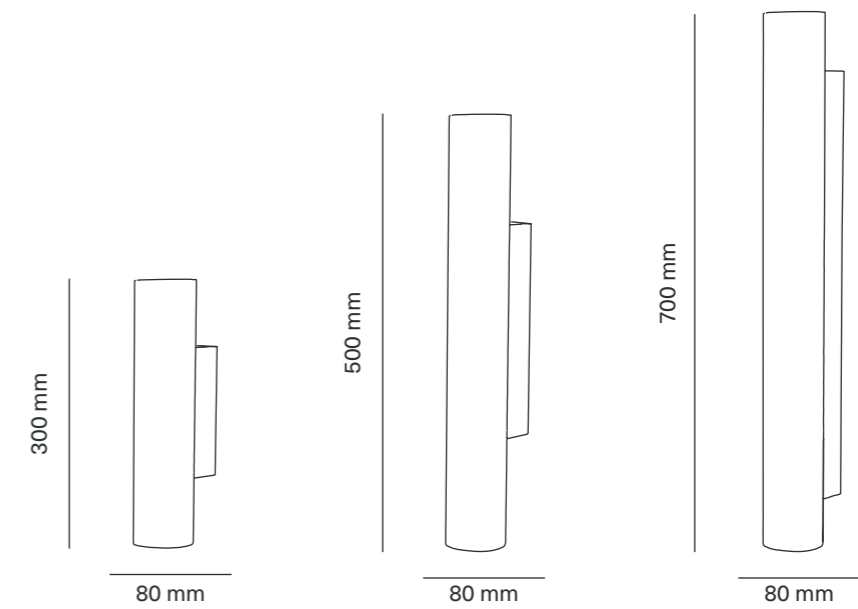



Kendō 2 applique

Kendo (剣道) embodying the essence of the ‘way of the sword,’ this unique piece is anchored by a sturdy wooden base, infusing it with warmth and an authentic connection to tradition. Illuminate your space with the poetic fusion of modern aesthetics and ancient wisdom, as this distinctive fixture invites you to reflect on the timeless meaning of Kendo, casting a luminous tribute to its rich cultural significance.



Kendō 2 applique

Materials	Alabaster
Finishes	Wood, Matt Black
Light source	1 x Strip LED, 21,6 W/m 3000 K

Dimensions

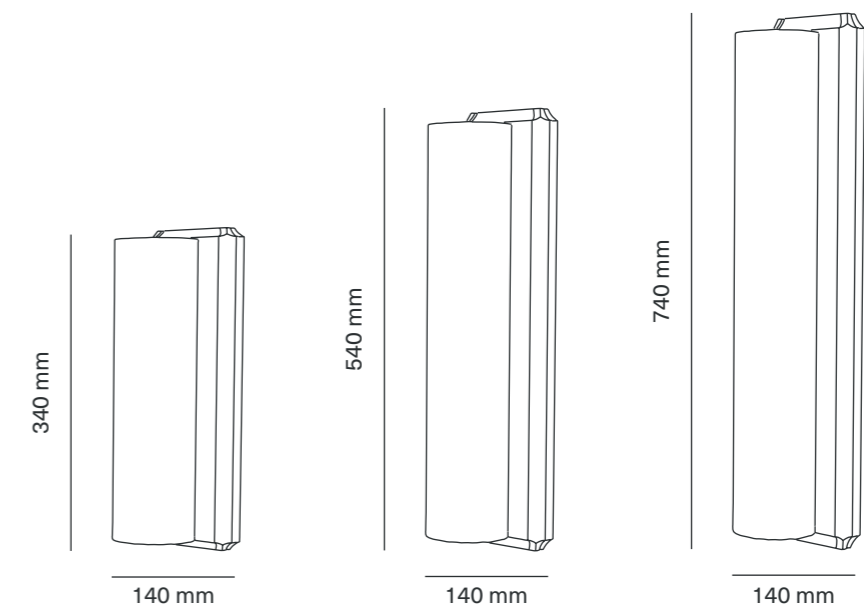



Tsuki applique

Tsuki (月) inspired by the serene beauty of the Japanese moonlit nights, captures the essence of celestial elegance. This alabaster applique serves as a symbolic bridge between nature and art, seamlessly blending cultural richness with modern aesthetics.

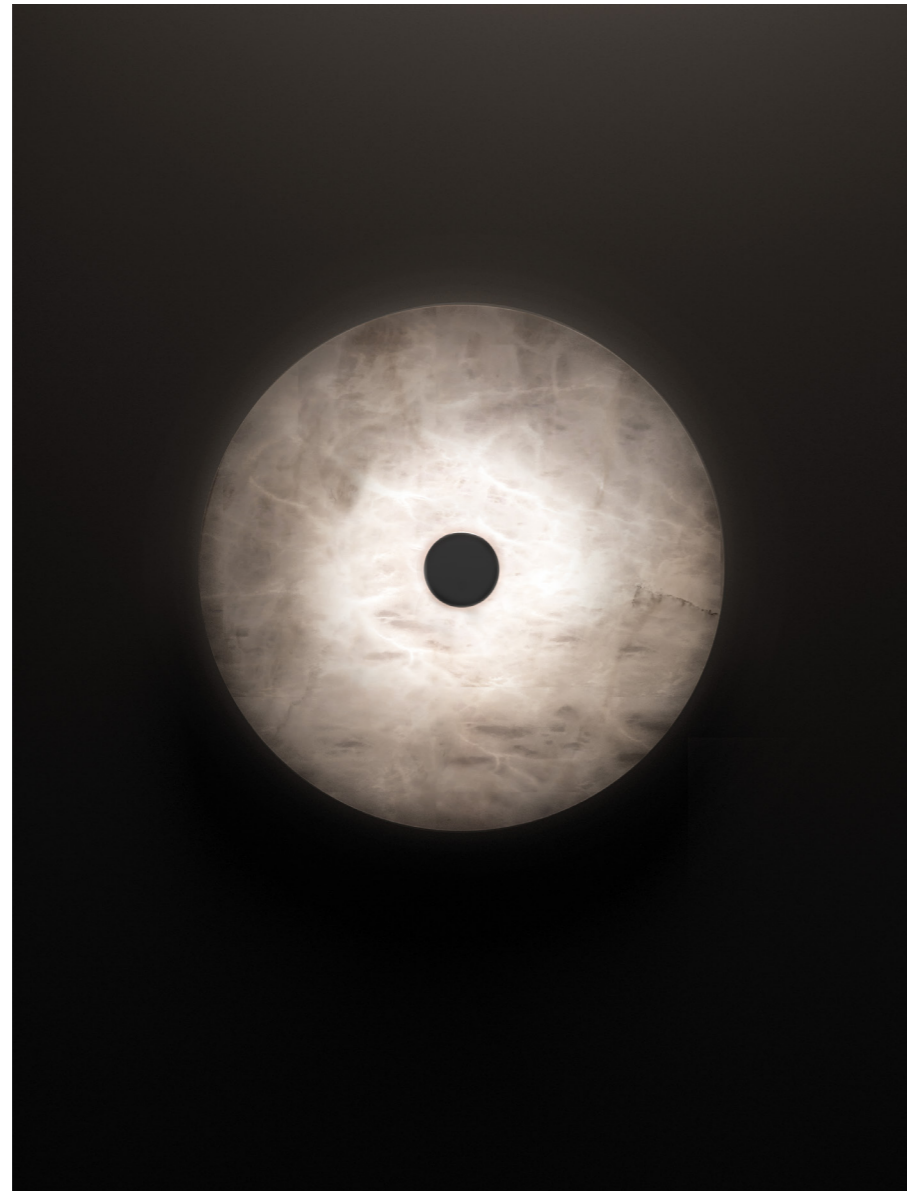

Tsuki applique

Materials	Alabaster
Finishes	Shiny Silver, Bronze, Brushed Brass, Ruggine of Florence, Brushed Burnished, Shiny Gold, Brushed Black, Freedom Green, Shiny Black, Copper, Matt Black, Iroko Wood
Light source	1 x Strip LED, 21,6 W/m 3000 K

Dimensions

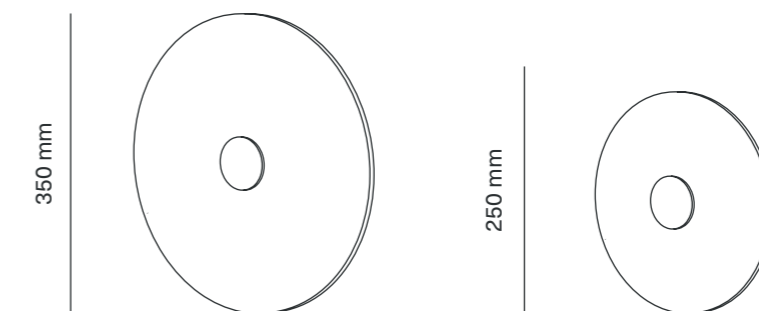



Hakuyoru pendants

Hakuyoru (白夜) embodies an intriguing synergy between white and night, translating this harmony into an essential design with its cylindrical shape. Its minimalist and elegant design is an ode to the purity and serenity of white, while its ability to diffuse a soft light emanates an atmosphere of tranquility and mystery, evoking the allure of the night.



Hakuyoru pendants

Materials	Alabaster
Finishes	Shiny Silver, Bronze, Brushed Brass, Ruggine of Florence, Brushed Burnished, Shiny Gold, Brushed Black, Freedom Green, Shiny Black, Copper, Matt Black
Light source	1 x GU10, 6 W 3000 K

Dimensions

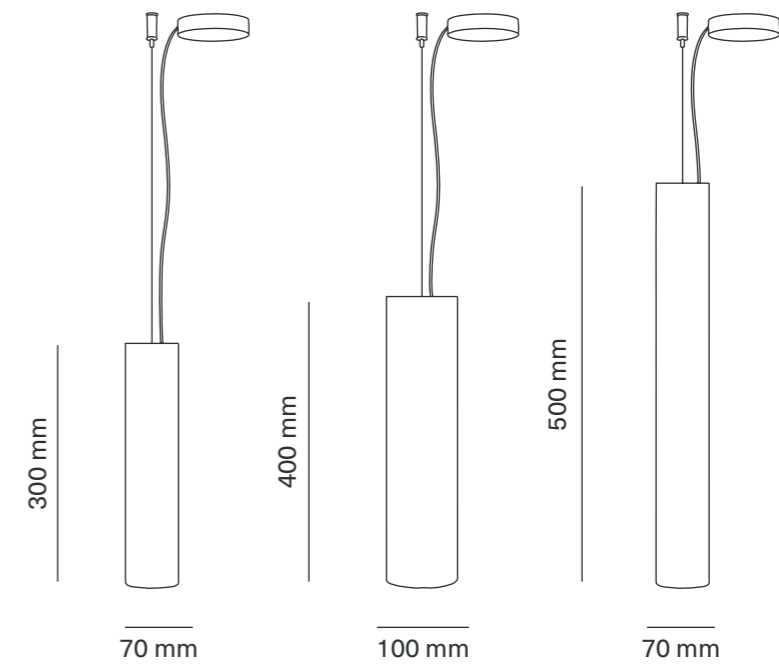



Futatsu suspension

Futatsu (二つ) invites you to explore the captivating beauty that arises from division and unity, reflecting the inherent balance found in pair where the beauty of one half finds its true significance in the presence of the other. The alabaster, with its unique texture and translucency, becomes a canvas for duality of opposing forces and the equilibrium that arises when they dance together.



Futatsu suspension

Materials	Alabaster
Finishes	Shiny Silver, Bronze, Brushed Brass, Ruggine of Florence, Brushed Burnished, Shiny Gold, Brushed Black, Freedom Green, Shiny Black, Copper, Matt Black
Light source	2 x Strip LED, 21,6 W/m 3000 K

Dimensions

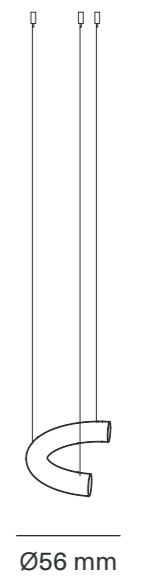
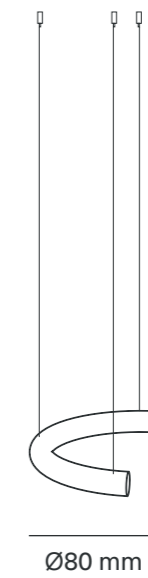
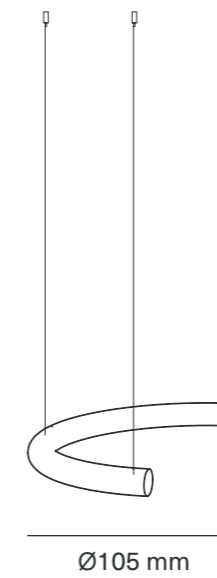



Demetra round pendant

Demetra goddess of flora, sister of Zeus, fully reflects the particular shape of this pendant. The spheres, of pure hand-turned alabaster, look like fruits hanging from the branches of a hypothetical tree of light. These brilliant elements stand out between heaven and earth and symbolise the richness that only Mother Nature can offer us.



Demetra round pendant

Materials	Alabaster
Finishes	Shiny Silver, Bronze, Brushed Brass, Ruggine of Florence, Brushed Burnished, Shiny Gold, Brushed Black, Freedom Green, Shiny Black, Copper, Matt Black
Light source	10 x LED, 30 W 3000 K

Dimensions

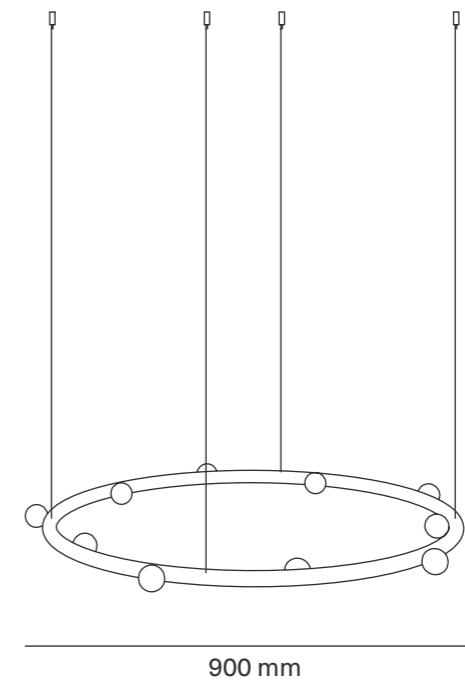



Serenity Fusion coffee tables

“Serenity” represents the serenity and calm which this design piece inspires, thanks to its elegant combination of natural materials.

“Fusion” underlines the harmonious fusion of two different elements such as Alabaster and Iroko wood, which come together in a single piece, creating a strong balance between strength and delicacy. This name instills a sense of tranquility and refinement, inviting people to enjoy an unparalleled design experience, conveying a feeling of peace and sophistication when gathering around this coffee table.



Serenity Fusion coffee tables

Materials

Alabaster, Iroko Wood

Finishes

Shiny Silver, Bronze, Brushed Brass, Ruggine of Florence, Brushed Burnished, Shiny Gold, Brushed Black, Freedom Green, Shiny Black, Copper, Matt Black

Dimensions

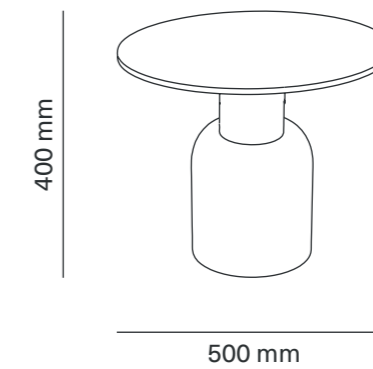



Serenity Fusion coffee tables

Materials

Alabaster, Iroko Wood

Finishes

Shiny Silver, Bronze, Brushed Brass, Ruggine of Florence, Brushed Burnished, Shiny Gold, Brushed Black, Freedom Green, Shiny Black, Copper, Matt Black

Dimensions

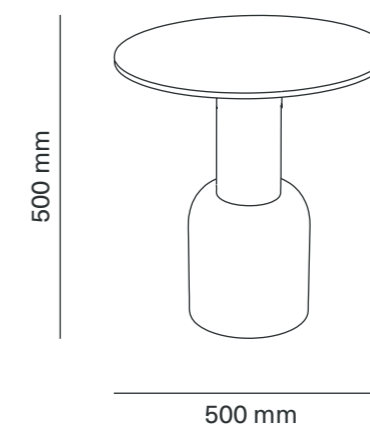



Sekishō counter

Sekishō (石灯) combines the words 'stone' and 'lamp' in its name. Made from precious wood and alabaster slabs, Sekishō conveys an impression of solidity and sturdiness, just like stone. The alabaster, when illuminated, transforms the counter into a lamp, creating an atmosphere enveloping and suggestive atmosphere. Sekishō represents a harmonious fusion of art and functionality.



Sekishō counter

Materials Alabaster, Wood

Finishes Brushed Burnished

Light source 8 x Strip LED, 10 W/m
2700 K

Dimensions

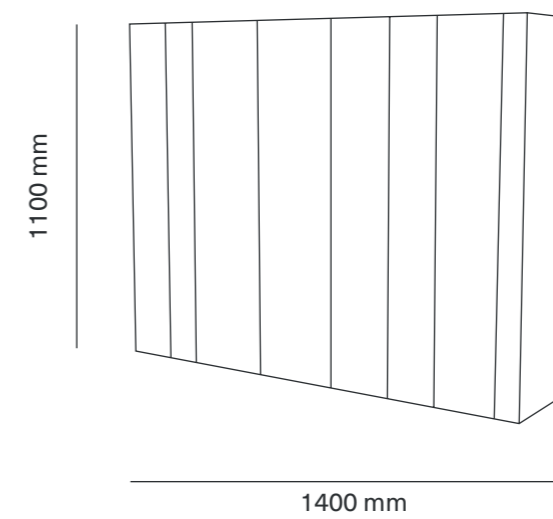



OGI track spotlights

The name “OGI” was chosen to represent the collection in a meaningful and evocative way.

It is inspired by the symbol of the fan in Japanese culture, an icon of grace, elegance and refinement.

These values recalled by the fan are deeply rooted in Japanese culture, reflecting an art that combines craftsmanship and precision, characteristics that directly relate to the product.

Moreover, “OGI” is a tribute to the product’s ancient history, rooted in enduring craft traditions. Alabaster, the main material in your collection, is known for its preciousness and its workmanship requires craftsmanship that has been passed down from generation to generation.



OGI track spotlights

Materials	Aluminium
Finishes	Shiny Silver, Bronze, Brushed Brass, Ruggine of Florence, Brushed Burnished, Shiny Gold, Brushed Black, Freedom Green, Shiny Black, Copper, Matt Black
Light source	3000K, 12 Watt, Beam Angle 15°, IP 20

Dimensions

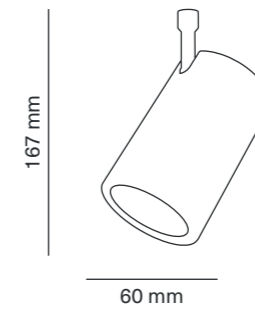



OGI track spotlights

Materials	Aluminium, Alabaster
Finishes	Shiny Silver, Bronze, Brushed Brass, Ruggine of Florence, Brushed Burnished, Shiny Gold, Brushed Black, Freedom Green, Shiny Black, Copper, Matt Black
Light source	3000K, 12 Watt, Beam Angle 15°, IP 20

Dimensions

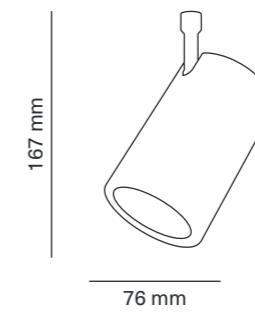



OGI track spotlights

Materials

Aluminium, Alabaster

Finishes

Shiny Silver, Bronze, Brushed Brass, Ruggine of Florence, Brushed Burnished, Shiny Gold, Brushed Black, Freedom Green, Shiny Black, Copper, Matt Black

Light source

3000K, 12 Watt, IP 20

Dimensions

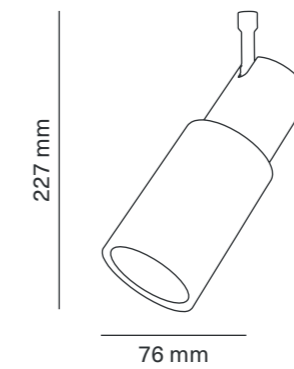

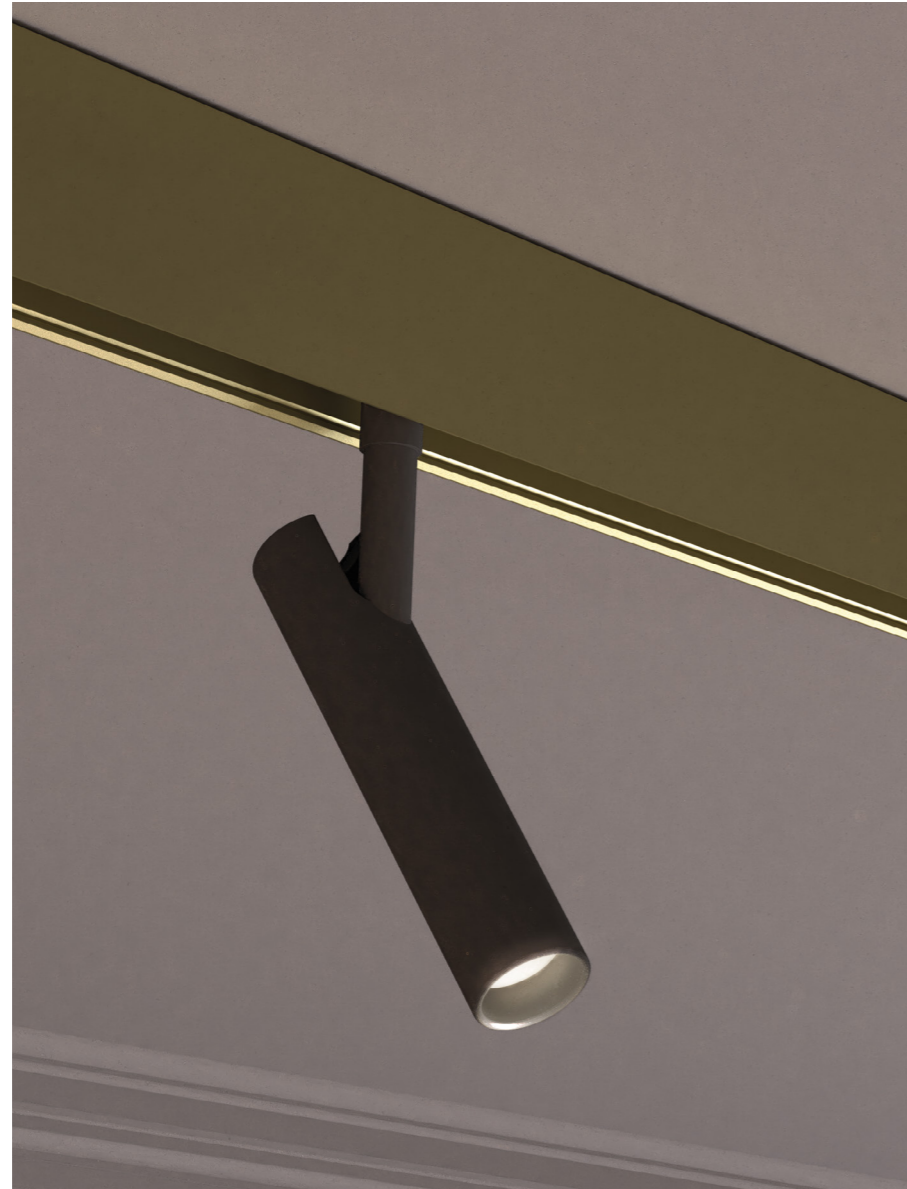

OGI track spotlights

Materials	Aluminium
Finishes	Shiny Silver, Bronze, Brushed Brass, Ruggine of Florence, Brushed Burnished, Shiny Gold, Brushed Black, Freedom Green, Shiny Black, Copper, Matt Black
Light source	3000K, 4,5 Watt, Beam Angle 38°, IP 20

Dimensions

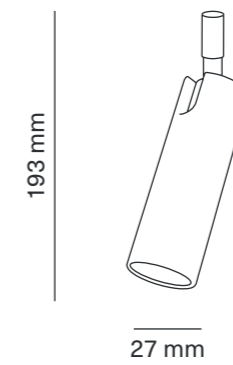



OGI track spotlights

Materials	Alabaster
Finishes	Shiny Silver, Bronze, Brushed Brass, Ruggine of Florence, Brushed Burnished, Shiny Gold, Brushed Black, Freedom Green, Shiny Black, Copper, Matt Black
Light source	3000K, 4,5 Watt, Angle 38°, IP 20

Dimensions

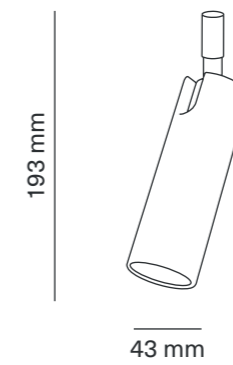



OGI track spotlights

Materials

Aluminium, Alabaster

Finishes

Shiny Silver, Bronze, Brushed Brass, Ruggine of Florence, Brushed Burnished, Shiny Gold, Brushed Black, Freedom Green, Shiny Black, Copper, Matt Black

Light source

3000K, 4,5 Watt, IP 20

Dimensions

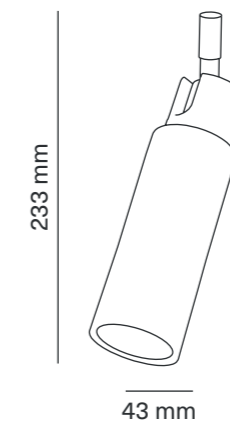



Henka spotlights

Henka (変化) the very name evokes the concept of change. This lamp embodies the essence of versatility and elegance in a single product. Available in a variety of high-quality materials, Henka fits into any environment and style, representing a perfect synthesis of functionality and beauty. Its presence illuminates spaces with timeless elegance.



Henka spotlights

Materials

Alabaster, Iroko Wood

Light source

1 x GU10, 6 Watt
3000 K

Dimensions

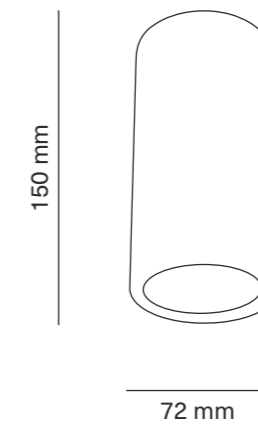



Enkō ceiling light

Enkō (円光) is inspired by the Enso symbol, which represents Enlightenment, strength, the Universe and the emptiness. This extraordinary lighting piece captures the essence of these meanings, creating an elegant and enchanting circle of light. Its circular shape, like a ring of light, projects a feeling of completeness and harmony, while its diffused light conveys an atmosphere of serenity and reflection. The Enkō ceiling light is more than just a lighting object; it is a symbol of beauty, depth and transformation



Enkō ceiling light

Materials	Alabaster
Finishes	Shiny Silver, Bronze, Brushed Brass, Ruggine of Florence, Brushed Burnished, Shiny Gold, Brushed Black, Freedom Green, Shiny Black, Copper, Matt Black
Light source	LED module, 16 Watt 3000 K

Dimensions

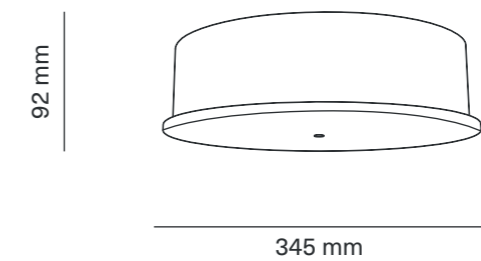



Eden wall panels

These panels seamlessly blend the elegance of nature with human craftsmanship, showcasing the organic forms found in the natural world. The translucent quality of Alabaster allows for a mesmerizing interplay of light and shadow, creating an ethereal ambiance. The series is aptly named “Eden” to evoke the concept of an idyllic paradise. The use of Alabaster, with its inherent luminosity and subtle variations, symbolizes the tranquility and purity associated with the mythical Garden of Eden.



Eden wall panels

Materials Alabaster

Light source Strip LED, 10 W/m

Dimensions

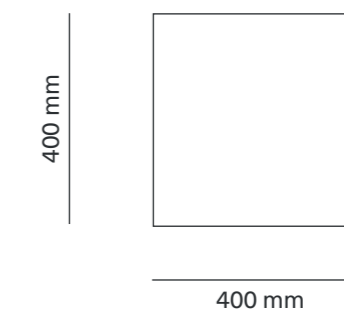
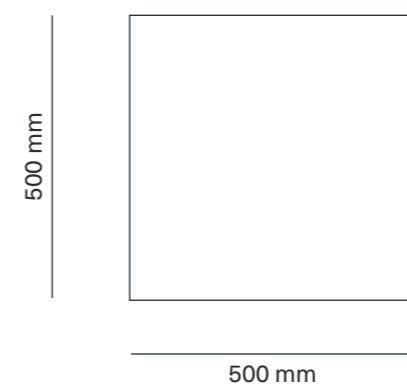
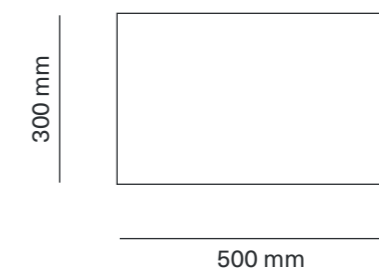
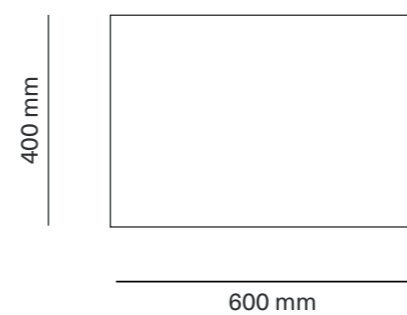

Concept & Design / Alabastro Italiano Studio

Graphic Design / Thomas Zandonà

Edition / 2024

By Ongarato Bespoke Lighting srl
Via Armistizio n. 221, 35142 PADOVA (PD)